

On the detection of a moving obstacle in an ideal fluid by a boundary measurement

Carlos Conca^{1,2}, Patricio Cumsille², Jaime Ortega^{2,3} and Lionel Rosier^{2,4}

¹ Departamento de Ingeniería Matemática (DIM), Universidad de Chile (UMI CNRS 2807), Avda Blanco Encalada 2120, Casilla 170-3, Correo 3, Santiago, Chile

² Centro de Modelamiento Matemático (CMM), Universidad de Chile (UMI CNRS 2807), Avda Blanco Encalada 2120, Casilla 170-3, Correo 3, Santiago, Chile

³ Depto. Ciencias Básicas, Fac. Ciencias, U. del Bío-Bío, Avda Andrés Bello, Chillán, Chile

⁴ Institut Elie Cartan, UMR 7502 UHP/CNRS/INRIA, BP 239, F-54506 Vandœuvre-lès-Nancy Cedex, France

E-mail: cconca@dim.uchile.cl, pcumsill@dim.uchile.cl, jortega@dim.uchile.cl
and rosier@iecn.u-nancy.fr

Received 4 December 2007, in final form 8 April 2008

Published 22 May 2008

Online at stacks.iop.org/IP/24/045001

Abstract

In this paper, we investigate the problem of the detection of a moving obstacle in a perfect fluid occupying a bounded domain in \mathbb{R}^2 from the measurement of the velocity of the fluid on one part of the boundary. We show that when the obstacle is a ball, we may identify the position and the velocity of its centre of mass from a single boundary measurement. Linear stability estimates are also established by using shape differentiation techniques.

1. Introduction

Inverse problems in fluid mechanics constitute a challenging topic with numerous potential applications, ranging from engineering, medicine, and military surveillance to fishing. In [4], the authors established that a fixed smooth convex obstacle surrounded by a real fluid modelled by Navier–Stokes equations could be identified via a localized boundary measurement of the velocity of the fluid and the Cauchy forces. Directional stability estimates were also derived in the same paper. The results in [4] strongly rested on the unique continuation property for the Stokes system due to Fabre–Lebeau [8]. In [6] the obstacle was identified by a measurement of both the gradient of the pressure and the velocity of the fluid on a part of the boundary, and the stability was established by shape differentiation. The distance from a chosen point to the obstacle was estimated in [10] from boundary measurements for a fluid governed by the stationary Stokes equation. As water is often considered as a perfect fluid on a small time-scale, it is natural to wonder whether the above results are still valid when the viscosity coefficient tends to zero, i.e., for an ideal fluid. The answer to that question is of great importance for applications.

In this paper, we shall address the issue of whether a moving obstacle surrounded by a perfect fluid may be detected by the measurement of the tangential velocity of the fluid on one part of the boundary. Assume a fixed domain $\Omega \subset \mathbb{R}^2$, and a rigid body S occupying the set $S(t) \subset \Omega$ at time t . Let us denote by $h(t)$ the centre of mass of $S(t)$, m the mass of the rigid body and J its moment of inertia. Then the equations modelling the dynamics of the system solid + fluid read [19] as follows:

$$\frac{\partial u}{\partial t} + (u \cdot \nabla)u + \nabla p = 0 \quad (x, t) \in (\Omega \setminus S(t)) \times \mathbb{R}, \quad (1.1)$$

$$\operatorname{div} u = 0 \quad (x, t) \in (\Omega \setminus S(t)) \times \mathbb{R}, \quad (1.2)$$

$$u \cdot n = (h' + r(x - h)^\perp) \cdot n \quad (x, t) \in \partial S(t) \times \mathbb{R}, \quad (1.3)$$

$$u \cdot n = g \quad (x, t) \in \partial \Omega \times \mathbb{R}, \quad (1.4)$$

$$mh''(t) = \int_{\partial S(t)} pn \, d\sigma + f(t) \quad t \in \mathbb{R}, \quad (1.5)$$

$$Jr'(t) = \int_{\partial S(t)} (x - h(t))^\perp \cdot pn \, d\sigma + T(t) \quad t \in \mathbb{R}. \quad (1.6)$$

In these equations, $u = u(x, t)$ (resp. $p = p(x, t)$) is the velocity (resp. the pressure) of the fluid, g is the flow through the boundary Ω (just assumed to be given here), r is the angular velocity of the solid, $x^\perp = (-x_2, x_1)$ if $x = (x_1, x_2)$, n is the outward unit normal vector and $f(t)$ (resp. $T(t)$) stands for the external force (resp. the external torque) applied to the solid in addition to the contribution of the fluid pressure represented by the integral term. For a rigid body without a self-propelling mechanism (i.e. $f = T = 0$) moving in the whole space ($\Omega = \mathbb{R}^2$), it has been proved that system (1.1)–(1.6) admits a unique classical solution defined for all times in [18, 19]. When Ω is a half-plane, the existence of chocks in finite time between the rigid body and the boundary of the domain has been established in [12] when S is a ball and u is a potential velocity.

In this paper, we focus on the determination of the position and the velocity of the obstacle from a boundary measurement of the velocity of the fluid at a given time t . This means that we will ignore the Newton laws (1.5) and (1.6) in our analysis. This setting is convenient in situations where the self-propelling data, namely f and T , are not known. This is the case, for example, when we aim to localize a submarine from a pressure measurement.

In contrast to what happens for Navier–Stokes equations, the Euler equations do not exhibit any unique continuation property because of the existence of the famous *ghost solutions* with compact support [16]. A simple example of a ghost solution is provided by the stationary solution $v(x) = (\partial\psi/\partial x_2, -\partial\psi/\partial x_1)$, where the stream function ψ is given by

$$\psi(x) = - \int_1^{|x|} \frac{1}{r} \left(\int_1^r s\omega(s) \, ds \right) dr$$

and the vorticity $\omega \in C^\infty(\mathbb{R}^+)$ is chosen so that $\omega(s) = 0$ for $s \geq 1$ and $\int_r^1 s\omega(s) \, ds = 0$ for $r \in (0, r_0)$, where $r_0 \in (0, 1)$ is a given number. As v is supported in the set $\{r_0 \leq |x| \leq 1\}$, we deduce that no obstacle contained in the ball $B_{r_0}(0)$ can be detected from measurements performed at a distance from the origin larger than 1; that is, the identifiability property fails for Eulerian flows.

However, the above obstruction to the detection disappears if we restrict ourselves to potential flows, that is, flows for which the velocity assumes the form $v = \nabla\varphi$ for a scalar function $\varphi = \varphi(x, t)$. It is well known (see, e.g. [17]) that a bidimensional Eulerian flow in

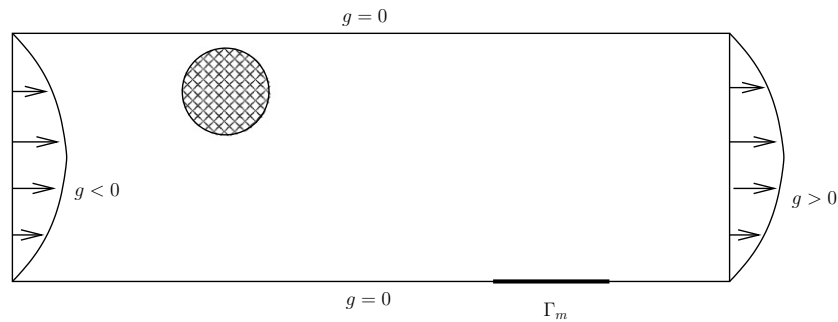

Figure 1. Moving obstacle in a pipeline.

a domain with one hole S is potential if the vorticity vanishes everywhere and the circulation along S is null. As it has been noticed in [13], an Eulerian flow remains potential as long as the incoming flow, located at the part of the boundary where $g < 0$, has a null vorticity. We shall assume that the incoming flow fulfils that condition.

Plugging $u = \nabla\varphi$ in (1.1)–(1.4) results in the system

$$\nabla\left(\frac{\partial\varphi}{\partial t} + \frac{1}{2}|\nabla\varphi|^2 + p\right) = 0 \quad (x, t) \in (\Omega \setminus S(t)) \times \mathbb{R}, \quad (1.7)$$

$$\Delta\varphi = 0 \quad (x, t) \in (\Omega \setminus S(t)) \times \mathbb{R}, \quad (1.8)$$

$$\frac{\partial\varphi}{\partial n} = (h' + r(x - h)^\perp) \cdot n \quad (x, t) \in \partial S(t) \times \mathbb{R}, \quad (1.9)$$

$$\frac{\partial\varphi}{\partial n} = g \quad (x, t) \in \partial\Omega \times \mathbb{R}. \quad (1.10)$$

Clearly, measuring the tangential component of the velocity on one part of the boundary amounts to measuring the function φ itself. When the obstacle is *fixed* ($h' = r = 0$), condition (1.9) simplifies to $\partial\varphi/\partial n = 0$, so that the detection of the obstacle reduces to a very classical problem (see, e.g. [1–3, 5, 9, 14, 22]). Such a problem arises in different contexts including the corrosion detection by electrostatic measurements and the crack detection in nonferrous metals from electromagnetic measurements.

As far as we know, the situation where the obstacle is moving (i.e. $(h, r) \neq (0, 0)$) has not yet been investigated. It turns out that this problem is more difficult to study than the stationary one for two reasons: (i) the velocity of the rigid body being *unknown*, the classical argument based upon the unique continuation property for the Laplace equation is not sufficient to derive the identifiability property; (ii) unlike [2, 9], we cannot use several Neumann data and apply topological arguments to identify the obstacle. Indeed, the obstacle may occupy different positions and undergo different velocities for different Neumann data.

The goal of this paper is to address the identifiability issue when the obstacle has a known form. For the sake of simplicity, we shall assume here that the obstacle is the ball $B_1(h(t))$ of radius one centred at the point $h(t)$. (See figure 1.) Note that, for any $x \in \partial B_1(h(t))$, $x - h(t) = -n$, hence $(x - h)^\perp \cdot n = 0$. Setting $l = h'$, the system reads

$$\Delta\varphi = 0 \quad \text{in } \Omega \setminus \overline{B_1(h(t))}, \quad (1.11)$$

$$\frac{\partial\varphi}{\partial n} = l \cdot n \quad \text{on } \partial B_1(h(t)), \quad (1.12)$$

$$\frac{\partial \varphi}{\partial n} = g \quad \text{on } \partial\Omega, \quad (1.13)$$

and we assume that φ is measured on a part Γ_m of the boundary $\partial\Omega$. The identifiability issue is to understand whether only one pair (h, l) may be associated with a given measurement.

Clearly, the data $g(x) = l \cdot x$, with $l \in \mathbb{R}^2$ a given fixed vector, has to be excluded, for it may lead to the situation where the ball, which is surrounded by a fluid flowing at the same velocity ($\varphi(x, t) = l \cdot x$), is not identifiable. We shall prove in this paper that for any data g which is not of this form, the identifiability problem has a positive answer, whatever be the distance between the ball and $\partial\Omega$.

The method of proof relies on a careful investigation of the singularities of the solution ψ to the Dirichlet problem

$$\Delta \psi = 0 \quad \text{in } B_1(h) \setminus \overline{B_1(-h)}, \quad (1.14)$$

$$\psi = y \quad \text{on } \partial B_1(h) \cap \{y > 0\}, \quad (1.15)$$

$$\psi = -y \quad \text{on } \partial B_1(-h) \cap \{y > 0\}, \quad (1.16)$$

where $h = (0, \delta)$ and $0 < \delta < 1$. More precisely, we will show that the solution ψ of (1.14)–(1.16) is not of the class C^2 at the point $M_+ = (\sqrt{1 - \delta^2}, 0)$ when $\delta \geq 1/\sqrt{2}$, and that ψ may be extended analytically on the set $B_1(-h) \cap \{y > 0\}$ when $\delta > 0$, by using a Möbius transformation and a version of Schwarz reflection principle for harmonic functions. It is likely that the function ψ fails to be analytic in a neighbourhood of M_+ for any $\delta > 0$, but despite our efforts, we were not able to prove it.

The second main objective of the paper is to investigate the stability properties of the map $\varphi|_{\Gamma_m} \rightarrow (h, l)$. Under the same assumption on the data g as above, we shall derive a linear stability estimate. The method of proof rests on the concept of shape differentiation introduced by Simon in [21].

To summarize, we present in this paper sharp results for the identification of a moving obstacle surrounded by a potential flow via a single boundary measurement, when the obstacle is a ball in \mathbb{R}^2 . It would be interesting to see whether these results can be extended to a smooth obstacle of *arbitrary (known)* form in dimension two. On the other hand, it is clear that more information can be collected by repeating measurements on a time interval. It would be interesting to see whether the *shape* of the obstacle could be identified with a measurement over a time interval. Finally, preliminary computations indicate that a single measurement of the fluid velocity on the boundary is probably not sufficient to extend the results of the paper to the dimension three. This suggests that repeating measurements over a time interval could be essential in dimension three. These issues, which are below the scope of this paper, will be investigated elsewhere.

The paper is outlined as follows. The identifiability result is stated and proved in section 2. Section 3 is devoted to the derivation of the stability estimate. Finally, the annexe contains the proof of the fact that ψ is not of class C^2 at M_+ when $\delta \geq 1/\sqrt{2}$.

2. Identifiability

Let Ω be a bounded (connected) open set in \mathbb{R}^2 , with a smooth boundary $\partial\Omega$. Assume given an open set Γ_m in $\partial\Omega$, and a function $g \in H^s(\partial\Omega)$, with $s \geq 0$, such that $\int_{\partial\Omega} g \, d\sigma = 0$. We denote by Ω_a the set of admissible positions for the centres of the balls of radius one included in Ω ; i.e.,

$$\Omega_a := \{h \in \Omega, \text{dist}(h, \partial\Omega) > 1\}.$$

Let $h_1, h_2 \in \Omega_a$ and $l_1, l_2 \in \mathbb{R}^2$. For $i = 1, 2$, we denote by B_i the ball $B_1(h_i)$, and by φ_i the solution (defined up to an additive constant) of the following Neumann problem:

$$\Delta\varphi_i = 0 \quad \text{in } \Omega \setminus \overline{B_i}, \quad (2.1)$$

$$\frac{\partial\varphi_i}{\partial n} = g \quad \text{on } \partial\Omega, \quad (2.2)$$

$$\frac{\partial\varphi_i}{\partial n} = l_i \cdot n \quad \text{on } \partial B_i, \quad (2.3)$$

where n stands for the outward unit normal vector. We shall say that problem (2.1)–(2.3) is *identifiable* if, for a convenient choice of the input g , the following implication holds:

$$\varphi_1 = \varphi_2 \quad \text{on } \Gamma_m \Rightarrow h_1 = h_2 \quad \text{and} \quad l_1 = l_2. \quad (2.4)$$

Let us introduce the two-dimensional space

$$V = \text{Span}\{e_1 \cdot n, e_2 \cdot n\} \subset L^\infty(\partial\Omega),$$

where $\{e_1, e_2\}$ denotes the canonical basis of \mathbb{R}^2 .

The following result is the first main result of this paper.

Theorem 2.1. *Assume that $g \in H^s(\partial\Omega) \setminus V$ with $s > 1/2$. For $i = 1, 2$, pick any $(h_i, l_i) \in \Omega_a \times \mathbb{R}^2$ and let φ_i denote the solution (defined up to a constant) of (2.1)–(2.3). Then (2.4) holds.*

Proof. By standard regularity results for elliptic problems [15], we know that $\varphi_i \in H^{s+3/2}(\Omega \setminus \overline{B_i}) \subset C^1(\overline{\Omega \setminus B_i})$. Assume that $\varphi_1 = \varphi_2$ on Γ_m . Since also $\frac{\partial\varphi_1}{\partial n} = g = \frac{\partial\varphi_2}{\partial n}$ on Γ_m , we infer from the unique continuation property that

$$\varphi_1 = \varphi_2 \quad \text{on } \Omega \setminus \overline{B_1 \cup B_2}.$$

Define a function $\varphi : \Omega \setminus \overline{B_1 \cap B_2} \rightarrow \mathbb{R}$ by

$$\varphi(x) := \begin{cases} \varphi_1(x) & \text{if } x \in \Omega \setminus \overline{B_1} \\ \varphi_2(x) & \text{if } x \in \Omega \setminus \overline{B_2}. \end{cases} \quad (2.5)$$

Then φ fulfils

$$\Delta\varphi = 0 \quad \text{in } \Omega \setminus \overline{B_1 \cap B_2}, \quad (2.6)$$

$$\frac{\partial\varphi}{\partial n} = g \quad \text{on } \partial\Omega, \quad (2.7)$$

$$\frac{\partial\varphi}{\partial n} = l_1 \cdot n \quad \text{on } \partial B_1, \quad (2.8)$$

$$\frac{\partial\varphi}{\partial n} = l_2 \cdot n \quad \text{on } \partial B_2. \quad (2.9)$$

If $B_1 \cap B_2 = \emptyset$, then φ is, as φ_2 , defined and harmonic in B_1 , and we infer from (2.8) that $\varphi(x) = l_1 \cdot x + \text{const}$ on B_1 . The same property holds on Ω by unique continuation. This gives $g = l_1 \cdot n$ on $\partial\Omega$, and hence $g \in V$, which is a contradiction.

The nontrivial case is the one for which $B_1 \cap B_2 \neq \emptyset$, i.e. $\|h_2 - h_1\| < 2$. Obviously, if $h_1 = h_2$, then (2.8) and (2.9) yield $l_1 = l_2$. Assume from now on that $h_1 \neq h_2$. If $l_1 = l_2$, then introducing the domain $D_1 = B_1 \setminus \overline{B_2}$, we see that φ solves

$$\Delta\varphi = 0 \quad \text{in } D_1, \quad (2.10)$$

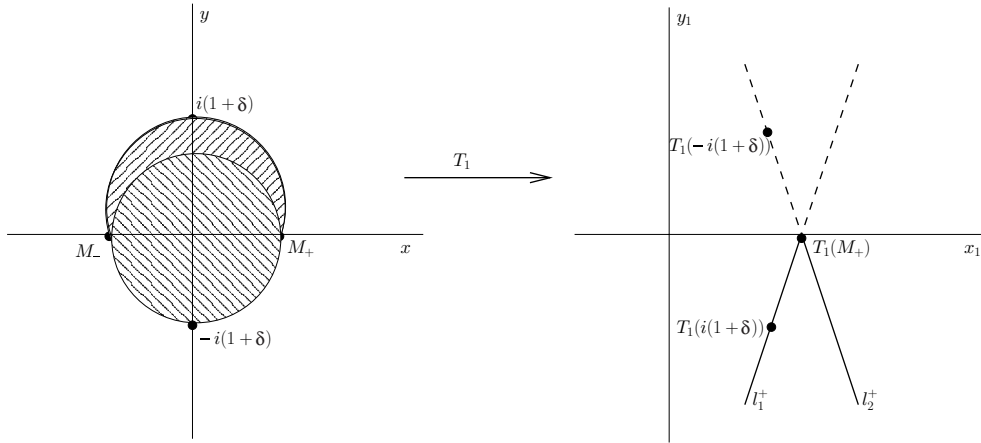

Figure 2. The Möbius transformation from D_1 to C_1 .

$$\frac{\partial \varphi}{\partial n} = l_1 \cdot n \quad \text{on } \partial D_1, \tag{2.11}$$

which gives again $\varphi(x) = l_1 \cdot x + \text{const}$ in D_1 and $g \in V$, which is a contradiction.

We shall therefore assume that $h_1 \neq h_2$ and $l_1 \neq l_2$. Using Green's formula, we infer from (2.10) and (2.8)–(2.9) that

$$(l_2 - l_1) \cdot (h_2 - h_1) = 0. \tag{2.12}$$

Translating and rotating Ω if needed, we may assume that $h_1 = (0, \delta)$, $h_2 = (0, -\delta)$ with $0 < \delta < 1$, and $l_2 - l_1 = \lambda e_1$ for some $\lambda \neq 0$. Replacing φ and g by $(-2/\lambda)(\varphi - l_1 \cdot x) + e_1 \cdot x$ and $(-2/\lambda)(g - l_1 \cdot n) + e_1 \cdot n$, respectively, we may assume that $l_1 = e_1$ and that $l_2 = -e_1$. We are thus led to investigate the properties of a function $\varphi : \Omega \setminus \overline{B_1} \cap \overline{B_2} \rightarrow \mathbb{R}$ satisfying the system

$$\Delta \varphi = 0 \quad \text{in } \Omega \setminus \overline{B_1} \cap \overline{B_2}, \tag{2.13}$$

$$\frac{\partial \varphi}{\partial n} = g \quad \text{on } \partial \Omega, \tag{2.14}$$

$$\frac{\partial \varphi}{\partial n} = e_1 \cdot n \quad \text{on } \partial B_1, \tag{2.15}$$

$$\frac{\partial \varphi}{\partial n} = -e_1 \cdot n \quad \text{on } \partial B_2. \tag{2.16}$$

We introduce the points $M_{\pm} = (\pm\sqrt{1 - \delta^2}, 0)$ located at the intersection of the circles ∂B_1 and ∂B_2 (see figure 2).

We shall use thereafter some complex analysis, denoting the coordinates by (x, y) instead of (x_1, x_2) , and identifying a couple (x, y) of real numbers with the complex number $z = x + iy$.

Pick a number $\eta > 0$ such that $B_{1+\eta}(h_1) \subset \Omega$. The function $\tilde{\varphi}(x, y) = \varphi(x, y) - x$ fulfils the system

$$\Delta \tilde{\varphi} = 0 \quad \text{on } B_{1+\eta}(h_1) \setminus \overline{B_1},$$

$$\frac{\partial \tilde{\varphi}}{\partial n} = 0 \quad \text{on } \partial B_1$$

and is of class C^1 on $\overline{\Omega} \setminus B_1$. By the reflection principle (see [11]), we may extend $\tilde{\varphi}$ to the annulus $\mathcal{A}_1 = B_{1+\eta}(h_1) \setminus \overline{B_{(1+\eta)^{-1}}(h_1)}$ as a harmonic function in setting

$$\tilde{\varphi}(z) = \tilde{\varphi}(\overline{(z - i\delta)^{-1} + i\delta}) \quad \text{for} \quad (1 + \eta)^{-1} < |z - i\delta| < 1.$$

Therefore, φ may as well be extended to \mathcal{A}_1 as a harmonic function. Analogously, φ may be extended as a harmonic function on the annulus $\mathcal{A}_2 = B_{1+\eta}(h_2) \setminus \overline{B_{(1+\eta)^{-1}}(h_2)}$. To obtain the contradiction, we shall prove that φ is also analytic in $B_1 \cap B_2$, so that by (2.15), $\varphi(x) = x \cdot e_1 + \text{const}$, and again $g \in V$, which contradicts the assumptions.

Since $\int_{\partial B_1} (\partial\varphi/\partial n) d\sigma = 0$, the function φ possesses a harmonic conjugate function ψ defined on $\mathcal{A}_1 \cup \mathcal{A}_2 \cup \Omega \setminus \overline{(B_1 \cap B_2)}$, fulfilling $\nabla\psi = (\nabla\varphi)^\perp$. Let θ (resp. θ') denote the angle $(\vec{e}_1, \vec{h}_1 \vec{M})$ (resp. $(\vec{e}_1, \vec{h}_2 \vec{M})$).

Then $\partial\psi/\partial\theta = \partial\varphi/\partial r = \cos\theta$ on ∂B_1 , which gives upon integration $\psi = \sin\theta + C$. Similarly, $\psi = -\sin\theta' + C'$ on ∂B_2 . Picking the constants C and C' so that $\psi(M_\pm) = 0$, we see that ψ solves

$$\Delta\psi = 0 \quad \text{in} \quad D_1 = B_1 \setminus \overline{B_2}, \tag{2.17}$$

$$\psi = y \quad \text{on} \quad \Gamma_1 := (\partial B_1) \setminus B_2, \tag{2.18}$$

$$\psi = -y \quad \text{on} \quad \gamma_2 := (\partial B_2) \cap B_1. \tag{2.19}$$

A similar Dirichlet problem is satisfied by ψ on $-D_1 = B_2 \setminus \overline{B_1}$, and from the uniqueness of the solution we infer that

$$\psi(x, -y) = \psi(x, y) = \psi(-x, y).$$

To prove that φ has no singularity in $B_1 \cap B_2$, it is therefore sufficient to check that ψ does not have any singularity in the set $B_2 \cap \{z = x + iy; y > 0\}$. We first transform problem (2.17)–(2.19) into a Dirichlet problem in a corner.

Let $T_1 : z \mapsto z_1 = x_1 + iy_1 = (z + \sqrt{1 - \delta^2})^{-1}$ denote the inversion of pole $M_- = -\sqrt{1 - \delta^2}$. As T_1 is a Möbius transformation, it carries circles into circles or lines (see [11]). Since $T_1(M_-) = \infty$, we see that $l_1 = T_1(\partial B_1)$ (resp. $l_2 = T_1(\partial B_2)$) is the line passing through $T_1(M_+) = (2\sqrt{1 - \delta^2})^{-1}$ and $T_1(i(1 + \delta)) = (-i + \sqrt{(1 - \delta)/(1 + \delta)})/2$ (resp. through $T_1(M_+)$ and $T_1(-i(1 + \delta)) = (i + \sqrt{(1 - \delta)/(1 + \delta)})/2$) (see figure 2). Clearly, $T_1(\Gamma_1)$ is the half-line $l_1^+ \subset l_1$ issuing from $T_1(M_+)$ and containing $T_1(i(1 + \delta))$, while $T_1(\gamma_2)$ is the half-line $l_2^+ \subset l_2$ issued from $T_1(M_+)$ and which does not contain $T_1(-i(1 + \delta))$. Therefore, $T_1(D_1)$ is the convex corner $C_1 = l_1^+ l_2^+$.

Note that $z = T_1^{-1}(z_1) = z_1^{-1} - \sqrt{1 - \delta^2}$. Let $\psi_1(z_1) := \psi(z)$. Then ψ_1 solves the system

$$\Delta\psi_1 = 0 \quad \text{in} \quad C_1, \tag{2.20}$$

$$\psi_1(z_1) = -\frac{y_1}{x_1^2 + y_1^2} \quad \text{on} \quad l_1^+, \tag{2.21}$$

$$\psi_1(z_1) = \frac{y_1}{x_1^2 + y_1^2} \quad \text{on} \quad l_2^+, \tag{2.22}$$

$$\psi_1(z_1) \rightarrow 0 \quad \text{as} \quad z_1 \rightarrow \infty, z_1 \in C_1. \tag{2.23}$$

For notational convenience, we translate and rotate the corner C_1 . We let $C_2 = T_2(C_1)$, where $T_2(z_1) := z_2 = -(z_1 - (2\sqrt{1 - \delta^2})^{-1})$. Then

$$C_2 = \left\{ z_2 \in \mathbb{C}^*; \frac{\pi - \theta}{2} < \arg z_2 < \frac{\pi + \theta}{2} \right\},$$

where $\theta \in (0, \pi)$ stands for the angle of C_1 at $T_1(M_+)$, or of ∂D_1 at M_+ by conformal invariance.

Let $\psi_2(z_2) := \psi_1(z_1)$. Then ψ_2 solves the system

$$\Delta \psi_2 = 0 \quad \text{in } C_2, \tag{2.24}$$

$$\psi_2(z_2) = \frac{y_2}{(x_2 + c)^2 + y_2^2} \quad \text{on } d_{-1}, \tag{2.25}$$

$$\psi_2(z_2) = -\frac{y_2}{(x_2 + c)^2 + y_2^2} \quad \text{on } d_0, \tag{2.26}$$

$$\psi_2(z_2) \rightarrow 0 \quad \text{as } z_2 \rightarrow \infty, z_2 \in C_2, \tag{2.27}$$

where $c := -(2\sqrt{1 - \delta^2})^{-1}$, and for any $k \in \mathbb{Z}$, d_k denotes the half-line

$$d_k = \left\{ z_2 \in \mathbb{C}^*; \arg z_2 = \theta_k := \frac{\pi + (2k + 1)\theta}{2} \right\}.$$

Note that $(T_2 \circ T_1)(B_2 \cap \{y > 0\})$ is the corner $C = \{z_2 \in \mathbb{C}^*; \theta_0 < \arg z_2 < \pi\}$. To prove that ψ does not have singularities in $B_2 \cap \{y > 0\}$, it is then sufficient to check that ψ_2 can be extended as a harmonic function on C . This is done in applying several times the following reflection principle for harmonic functions. \square

Lemma 2.2. *Let $\theta_0 \in \mathbb{R}$ and $\theta \in (0, \pi/2)$. Let $l_{\pm} = \{z \in \mathbb{C}^*; \arg z = \theta_0 \pm \theta\}$, and let $l_0 = \{z \in \mathbb{C}^*; \arg z = \theta_0\}$. Let $C_+ = \{z \in \mathbb{C}^*; \theta_0 < \arg z < \theta_0 + \theta\}$ (resp. $C_- = \{z \in \mathbb{C}^*; \theta_0 - \theta < \arg z < \theta_0\}$) be the sectors bounded by the half-lines l_0 and l_+ (resp. by the half-lines l_- and l_0). Let ψ be a harmonic function on C_- such that*

$$\lim_{z \rightarrow Z, z \in C_-} \psi(z) = \text{Im } f_-(Z) \quad \forall Z \in l_-, \tag{2.28}$$

$$\lim_{z \rightarrow Z, z \in C_-} \psi(z) = \text{Im } f_0(Z) \quad \forall Z \in l_0, \tag{2.29}$$

where f_- (resp. f_0) is a holomorphic function in a neighbourhood of l_- (resp. on $C_- \cup l_0 \cup C_+$). Then ψ can be extended as a harmonic function on the set $C_- \cup l_0 \cup C_+$, and

$$\lim_{z \rightarrow Z, z \in C_+} \psi(z) = -\text{Im } f_-(e^{-2i\theta} Z) + \lim_{z \rightarrow Z, z \in C_+} \text{Im}(f_0(z) + f_0(e^{2i\theta_0} \bar{z})) \tag{2.30}$$

for each $Z \in l_+$ for which the limit in the right-hand side of (2.30) exists.

Proof. Using the transformation $z \mapsto e^{-i\theta_0} z$, we may without loss of generality assume that $\theta_0 = 0$, hence $l_+ = \bar{l}_-$ and $C_+ = \bar{C}_-$, ($\bar{\cdot}$ means conjugation). Pick a holomorphic function f on C_- such that $\psi(z) = \text{Im } f(z)$ on C_- , and let $F(z) := f(z) - f_0(z)$. Then F is holomorphic on C_- , and for any $Z \in l_0$

$$\lim_{z \rightarrow Z, z \in C_-} \text{Im } F(z) = \lim_{z \rightarrow Z, z \in C_-} \psi(z) - \text{Im } f_0(Z) = 0$$

by (2.29). Using the Schwarz reflection principle for holomorphic functions stated in [20], we infer that F may be extended as an holomorphic function on $C_- \cup l_0 \cup C_+$ in setting

$$F(z) = \overline{F(\bar{z})} \quad \forall z \in C_+.$$

Letting

$$\psi(z) = \text{Im}(F(z) + f_0(z)) \quad \forall z \in C_+ \cup l_0,$$

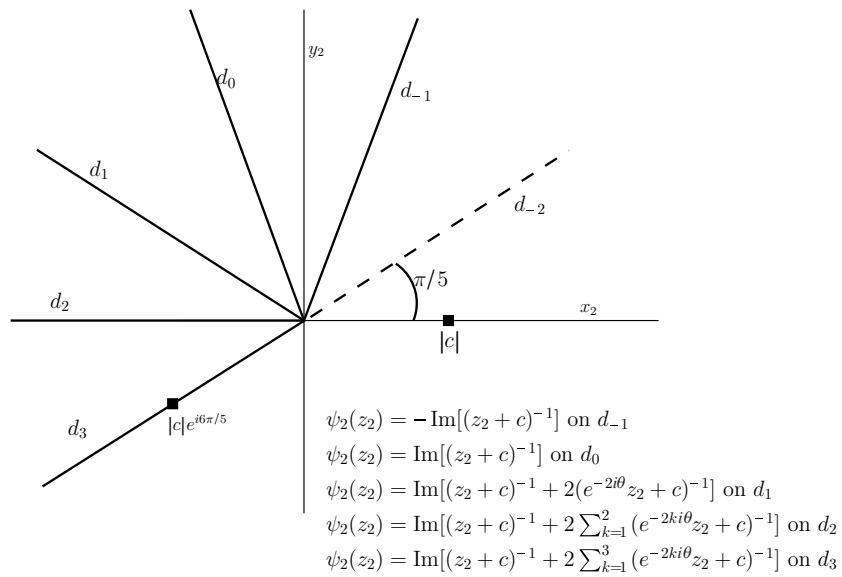

Figure 3. Analytic extension of ψ_2 when $\theta = \pi/5$.

we obtain a harmonic extension of ψ on $C_- \cup l_0 \cup C_+$. For $Z \in l_+$, we have

$$\begin{aligned}
 \lim_{z \rightarrow Z, z \in C_+} \psi(z) &= \lim_{z \rightarrow Z, z \in C_+} \text{Im}(\overline{F(z)} + f_0(z)) \\
 &= \lim_{z \rightarrow Z, z \in C_+} \text{Im}(\overline{f(z)} - \overline{f_0(z)} + f_0(z)) \\
 &= - \lim_{z \rightarrow Z, z \in C_+} \psi(\overline{z}) + \lim_{z \rightarrow Z, z \in C_+} \text{Im}(f_0(\overline{z}) + f_0(z)) \\
 &= -\text{Im} f_-(\overline{Z}) + \lim_{z \rightarrow Z, z \in C_+} \text{Im}(f_0(z) + f_0(\overline{z}))
 \end{aligned} \tag{2.31}$$

whenever the limit in (2.31) does exist. □

To see that ψ_2 can be extended in an analytic way on the sector C , we apply inductively lemma 2.2. Starting with $(l_+, l_0, l_-) = (d_1, d_0, d_{-1})$ and $f_-(z_2) = -(z_2 + c)^{-1}$, $f_0(z_2) = (z_2 + c)^{-1}$, we obtain for $\arg z_2 = \theta_1$

$$\psi_2(z_2) = \text{Im} \left(\frac{2}{e^{-2i\theta}z_2 + c} + \frac{1}{z_2 + c} \right). \tag{2.32}$$

Note that $\arg(e^{-2i\theta}z_2) = -2\theta + \theta_1 = \theta_{-1} > 0$, and hence the right-hand side of (2.32) is well defined on d_1 . (Recall that $c < 0$.)

Applying again lemma 2.2 with $(l_+, l_0, l_-) = (d_2, d_1, d_0)$ and

$$f_-(z) = \frac{1}{z_2 + c}, \quad f_0(z_2) = \frac{2}{e^{-2i\theta}z_2 + c} + \frac{1}{z_2 + c},$$

it follows that for $\arg z_2 = \theta_2$,

$$\psi_2(z_2) = \text{Im} \left(\frac{2}{e^{-4i\theta}z_2 + c} + \frac{2}{e^{-2i\theta}z_2 + c} + \frac{1}{z_2 + c} \right).$$

Assume first that $\theta = \frac{\pi}{2N+1}$ for some $N \in \mathbb{N}^*$, so that $\theta_N = \pi$. Then, we can prove by induction on k that for each $k \in \{1, \dots, N\}$ the function ψ_2 can be extended in an analytic way on the sector $d_{-1}d_k$, with

$$\psi_2(z_2) = \text{Im} \left(\frac{1}{z_2 + c} + \sum_{l=1}^k \frac{2}{e^{-2li\theta} z_2 + c} \right) \quad \forall z_2 \in d_k. \tag{2.33}$$

Note that for any $k \leq N$, the right-hand side of (2.33) does not present any singularity in the sector $d_{k-1}d_{k+1}$ (hence the extension at the step k can be performed), as

$$\arg(e^{-2ki\theta} z_2) > \theta_{k-1} - 2k\theta = \frac{\pi}{2} \left(1 - \frac{2k+1}{2N+1} \right) \geq 0.$$

A final application of lemma 2.2 gives that ψ_2 may be extended analytically on the sector $d_{-1}d_{N+1}$, with

$$\psi_2(z_2) = \text{Im} \left(\frac{1}{z_2 + c} + \sum_{l=1}^{N+1} \frac{2}{e^{-2li\theta} z_2 + c} \right) \tag{2.34}$$

for any $z \in d_{N+1}$ for which the right-hand side of (2.34) is meaningful. This occurs for any point of d_{N+1} , except for $z_2 = |c| e^{i\theta_{N+1}}$. This point is the first singularity encountered during the extension procedure of ψ_2 . As it is outside C , since $\theta_{N+1} \in (\pi, 2\pi)$, we are done.

Assume now that $\frac{\pi}{2N+3} < \theta < \frac{\pi}{2N+1}$ for some $N \in \mathbb{N}$. Then $\theta_N < \pi < \theta_{N+1}$. The analytic extension may be done in the sector $d_{-1}d_{N+1}$, as for $k \leq N$ and $\theta_{k-1} < \arg z_2 < \theta_{k+1}$ we have

$$\arg(e^{-2ki\theta} z_2) > \theta_{k-1} - 2k\theta = \frac{\pi}{2} - \frac{2k+1}{2}\theta \geq \frac{\pi}{2} - \frac{2N+1}{2}\theta > 0.$$

Once again, the analytic extension of ψ_2 does not present any singularity in C . The proof of theorem 2.1 is complete.

Remark 2.3. The above proof of theorem 2.1 is still valid when $g = 0$ and $l_1 \neq 0$. Indeed, the relation $l_1 \cdot n = 0$ cannot hold everywhere on $\partial\Omega$. This means that, in the absence of flow through the boundary, the obstacle can be identified when it is moving, and only in that case.

3. Stability estimates

In this section, we investigate the stability properties of the map $\varphi|_{\Gamma_m} \rightarrow (h, l)$. Linear stability estimates will be established by using shape differentiation.

Fix $h_0 \in \Omega_a, l_0 \in \mathbb{R}^2$ and a function g fulfilling

$$g \in H^s(\partial\Omega) \quad \text{for some } s \geq 1 \quad \text{and} \quad \int_{\partial\Omega} g \, d\sigma = 0. \tag{3.1}$$

Write $B_0 = B_1(h_0)$. Let φ_0 denote the solution of the *reference* Neumann problem

$$\Delta\varphi_0 = 0 \quad \text{in } \Omega \setminus \overline{B_0}, \tag{3.2}$$

$$\frac{\partial\varphi_0}{\partial n} = g \quad \text{on } \partial\Omega, \tag{3.3}$$

$$\frac{\partial\varphi_0}{\partial n} = l_0 \cdot n \quad \text{on } \partial B_0. \tag{3.4}$$

Pick any $(h, l) \in \Omega_a \times \mathbb{R}^2$, and let φ denote the solution of the *perturbed* Neumann problem

$$\Delta\varphi = 0 \quad \text{in } \Omega \setminus \overline{B}, \tag{3.5}$$

$$\frac{\partial \varphi}{\partial n} = g \quad \text{on } \partial \Omega, \quad (3.6)$$

$$\frac{\partial \varphi}{\partial n} = l \cdot n \quad \text{on } \partial B, \quad (3.7)$$

where $B = B_1(h)$. Once again, the functions φ and φ_0 are defined up to an additive constant. By standard regularity results for elliptic problems, we know that $\varphi \in H^{s+3/2}(\Omega \setminus \overline{B})$, hence $\varphi|_{\partial \Omega} \in H^{s+1}(\partial \Omega)$. We may therefore define a map $\Lambda : \Omega_a \times \mathbb{R}^2 \times \{g \in H^s(\partial \Omega); \int_{\partial \Omega} g \, d\sigma = 0\} \rightarrow H^{s+1}(\Gamma_m)/\mathbb{R}$ by

$$\Lambda(h, l, g) = \varphi|_{\Gamma_m}. \quad (3.8)$$

Recall that the quotient space $H^{s+1}(\Gamma_m)/\mathbb{R}$ is a Banach space for the norm

$$\|g\|_{H^{s+1}(\Gamma_m)/\mathbb{R}} := \inf_{t \in \mathbb{R}} \|g + t\|_{H^{s+1}(\Gamma_m)}.$$

Proceeding as in [4], one may prove that this map is of class C^1 . We are now in a position to state the second main result of the paper.

Theorem 3.1. *Let g fulfilling (3.1) and let $(h_0, l_0) \in \Omega_a \times \mathbb{R}^2$. If $g \notin V$, then there exist two constants $\rho > 0$ and $C > 0$ depending only on (h_0, l_0, g) such that for any $(h, l) \in B_\rho(h_0, l_0)$ we have*

$$\|\Lambda(h, l, g) - \Lambda(h_0, l_0, g)\|_{H^{s+1}(\Gamma_m)/\mathbb{R}} \geq C \|(h - h_0, l - l_0)\|_{\mathbb{R}^4}. \quad (3.9)$$

Proof. Let $d\Lambda(h_0, l_0, g)$ denote the differential of Λ at the point (h_0, l_0, g) , and let $L = d\Lambda(h_0, l_0, g)|_{\mathbb{R}^2 \times \mathbb{R}^2 \times \{0\}}$. We need the following result, whose proof will be postponed.

Proposition 3.2. *Let g be as in theorem 3.1. Then the map $L : \mathbb{R}^4 \rightarrow H^{s+1}(\Gamma_m)/\mathbb{R}$ is one-to-one.*

By the compactness of the unit sphere in \mathbb{R}^4 , we infer from proposition 3.2 the existence of two positive constants C_1, C_2 such that

$$C_1 \|(\hat{h}, \hat{l})\| \leq \|L(\hat{h}, \hat{l})\|_{H^{s+1}(\Gamma_m)/\mathbb{R}} \leq C_2 \|(\hat{h}, \hat{l})\| \quad \forall (\hat{h}, \hat{l}) \in \mathbb{R}^4. \quad (3.10)$$

On the other hand, we can write

$$\Lambda(h_0 + \hat{h}, l_0 + \hat{l}, g) = \Lambda(h_0, l_0, g) + L(\hat{h}, \hat{l}) + \|(\hat{h}, \hat{l})\| \varepsilon(\hat{h}, \hat{l}), \quad (3.11)$$

where $\varepsilon(h, l)$ is a function such that $\varepsilon(h, l) \rightarrow 0$ as $(h, l) \rightarrow 0$. Pick $\rho > 0$ so that $\|\varepsilon(\hat{h}, \hat{l})\| < C_1/2$ whenever $\|(\hat{h}, \hat{l})\| < \rho$. Then we infer from (3.10) and (3.11) that

$$\|\Lambda(h_0 + \hat{h}, l_0 + \hat{l}, g) - \Lambda(h_0, l_0, g)\|_{H^{s+1}(\Gamma_m)/\mathbb{R}} \geq (C_1/2) \|(\hat{h}, \hat{l})\|$$

for $\|(\hat{h}, \hat{l})\| < \rho$. The proof of theorem 3.1 is achieved.

It remains to prove proposition 3.2.

Proof of proposition 3.2. Let h_0, l_0 and g be as in the statement of theorem 3.1. Without loss of generality, we may assume that $h_0 = (0, 0)$.

If $(\hat{h}, \hat{l}) \in \mathbb{R}^4$ is given, then by a classical result due to Simon (see [21]) we have that $L(\hat{h}, \hat{l}) = \psi|_{\Gamma_m}$, where ψ denotes the solution (defined up to a constant) of

$$\Delta \psi = 0 \quad \text{in } \Omega \setminus \overline{B_0}, \quad (3.12)$$

$$\frac{\partial \psi}{\partial n} = 0 \quad \text{on } \partial \Omega, \quad (3.13)$$

$$\frac{\partial \psi}{\partial n} = -\hat{h} \cdot n \frac{\partial^2 \varphi_0}{\partial n^2} + (\nabla \varphi_0 - l_0) \cdot \text{grad}_{\partial \Omega}(\hat{h} \cdot n) + \hat{l} \cdot n \quad \text{on } \partial B_0, \quad (3.14)$$

φ_0 denoting the solution of (3.2)–(3.4), and $\text{grad}_{\partial \Omega}$ standing for the tangential gradient, defined as

$$\text{grad}_{\partial \Omega} f := \nabla f - (\nabla f \cdot n)n.$$

To prove the proposition, we argue by contradiction. If the map L is not one-to-one, then we can pick a pair $(\hat{h}, \hat{l}) \neq (0, 0)$ such that $L(\hat{h}, \hat{l}) = 0$, i.e. $\psi|_{\Gamma_m} = \text{const}$. Since $\frac{\partial \psi}{\partial n}|_{\Gamma_m} = 0$ and $\Delta \psi = 0$ in $\Omega \setminus \overline{B_0}$, we infer that $\psi \equiv \text{const}$ in $\Omega \setminus \overline{B_0}$ by unique continuation. Therefore, (3.14) gives

$$0 = -\hat{h} \cdot n \frac{\partial^2 \varphi_0}{\partial n^2} + (\nabla \varphi_0 - l_0) \cdot \text{grad}_{\partial \Omega}(\hat{h} \cdot n) + \hat{l} \cdot n \quad \text{on } \partial B_0. \quad (3.15)$$

Note that $\hat{h} \neq 0$, otherwise $\hat{l} = 0$ by (3.15). Let (r, θ) denote the polar coordinates with respect to the origin, and let $e_r := (\cos \theta, \sin \theta)$ and $e_\theta := e_r^\perp = (-\sin \theta, \cos \theta)$. Then $e_r = -n$ on ∂B_0 , so $\partial^2 \varphi_0 / \partial n^2 = \partial^2 \varphi_0 / \partial r^2$. Since $g \in H^1(\partial \Omega)$, we see that $\varphi_0 \in H^{\frac{5}{2}}(\Omega)$, hence all the second derivatives of φ_0 possess traces in $L^2(\partial B_0)$. In particular,

$$0 = \Delta \varphi_0 = \frac{\partial^2 \varphi_0}{\partial r^2} + \frac{1}{r} \frac{\partial \varphi_0}{\partial r} + \frac{1}{r^2} \frac{\partial^2 \varphi_0}{\partial \theta^2} \quad \text{on } \partial B_0. \quad (3.16)$$

On the other hand,

$$\nabla \varphi_0 = \frac{\partial \varphi_0}{\partial r} e_r + \frac{1}{r} \frac{\partial \varphi_0}{\partial \theta} e_\theta \quad \text{and} \quad \text{grad}_{\partial \Omega}(\hat{h} \cdot n) = \frac{\partial \hat{h} \cdot n}{\partial \theta} e_\theta \quad \text{on } \partial B_0. \quad (3.17)$$

Using (3.15)–(3.17), we obtain

$$\begin{aligned} 0 &= -\hat{h} \cdot n \left(-\frac{\partial \varphi_0}{\partial r} - \frac{\partial^2 \varphi_0}{\partial \theta^2} \right) + \left(\frac{\partial \varphi_0}{\partial r} e_r + \frac{\partial \varphi_0}{\partial \theta} e_\theta - l_0 \right) \cdot \frac{\partial \hat{h} \cdot n}{\partial \theta} e_\theta + \hat{l} \cdot n \\ &= -\hat{h} \cdot e_r \left(l_0 \cdot e_r + \frac{\partial^2 \varphi_0}{\partial \theta^2} \right) - \left(\frac{\partial \varphi_0}{\partial \theta} - l_0 \cdot e_\theta \right) \frac{\partial \hat{h} \cdot e_r}{\partial \theta} - \hat{l} \cdot e_r, \end{aligned}$$

and hence, gathering together the second derivatives with respect to θ ,

$$\frac{\partial}{\partial \theta} \left((\hat{h} \cdot e_r) \frac{\partial \varphi_0}{\partial \theta} \right) = (\hat{h} \cdot e_\theta)(l_0 \cdot e_\theta) - (\hat{h} \cdot e_r)(l_0 \cdot e_r) - \hat{l} \cdot e_r. \quad (3.18)$$

Let M_0 and M'_0 be the two points $M \in \partial B_0$ at which $\hat{h} \cdot e_r(M) = 0$, and let $\theta(M)$ denote the angle $(\overrightarrow{OM_0}, \overrightarrow{OM})$. Then, by (3.18),

$$\begin{aligned} \hat{h} \cdot e_r(M) \frac{\partial \varphi_0}{\partial \theta}(M) &= \int_0^{\theta(M)} \frac{\partial}{\partial \theta} \left(\hat{h} \cdot e_r \frac{\partial \varphi_0}{\partial \theta} \right) d\theta \\ &= \int_0^{\theta(M)} [(\hat{h} \cdot e_\theta)(l_0 \cdot e_\theta) - (\hat{h} \cdot e_r)(l_0 \cdot e_r)] d\theta - \int_0^{\theta(M)} \hat{l} \cdot e_r d\theta. \end{aligned}$$

As $de_r/d\theta = e_\theta$ and $de_\theta/d\theta = -e_r$, we obtain at once that

$$\int_0^{\theta(M)} [(\hat{h} \cdot e_\theta)(l_0 \cdot e_\theta) - (\hat{h} \cdot e_r)(l_0 \cdot e_r)] d\theta = [(\hat{h} \cdot e_r)(l_0 \cdot e_\theta)]_0^{\theta(M)}$$

and

$$\int_0^{\theta(M)} \hat{l} \cdot e_r d\theta = -\hat{l} \cdot [e_\theta]_0^{\theta(M)}.$$

We conclude that

$$\hat{h} \cdot e_r \frac{\partial \varphi_0}{\partial \theta} = [(\hat{h} \cdot e_r)(l_0 \cdot e_\theta) + \hat{l} \cdot e_\theta]_0^{(M)}.$$

Pick now $M = M'_0$, so that $\hat{h} \cdot e_r(M'_0) = 0$. We obtain

$$0 = \hat{l} \cdot (e_\theta(M'_0) - e_\theta(M_0)) = -2\hat{l} \cdot e_\theta(M_0).$$

It follows that $\hat{l} \in \text{Span}\{e_r(M_0)\}$, so

$$\hat{l} \cdot \hat{h} = 0.$$

Writing $\hat{l} = \lambda \hat{h}^\perp$ for some constant λ , we have that $\hat{l} \cdot e_\theta = \lambda \hat{h} \cdot e_r$, and thus

$$\hat{h} \cdot e_r \frac{\partial \varphi_0}{\partial \theta} = (\hat{h} \cdot e_r)(l_0 \cdot e_\theta) + \lambda \hat{h} \cdot e_r.$$

Dividing by $\hat{h} \cdot e_r$ (which is non-null for $M \neq M_0, M'_0$) and integrating over θ , we obtain $\varphi_0 = l_0 \cdot e_r + \lambda \theta + \mu$, where μ denotes another constant. The function φ_0 is therefore a solution to the system

$$\Delta \xi = 0 \quad \text{on} \quad \Omega \setminus \overline{B_0}, \quad (3.19)$$

$$\xi = l_0 \cdot x + \lambda \theta + \mu \quad \text{on} \quad \partial B_0, \quad (3.20)$$

$$\frac{\partial \xi}{\partial n} = l_0 \cdot n \quad \text{on} \quad \partial B_0. \quad (3.21)$$

An obvious solution of (3.19)–(3.21) on $\mathbb{C} \setminus (\mathbb{R}^- \cup \overline{B_0})$ is given by $\xi = l_0 \cdot x + \lambda \theta + \mu$. By the unique continuation property, we conclude that $\varphi_0 = \xi$. As φ_0 is continuous on $\overline{\Omega} \setminus B_0$, we infer that $\lambda = 0$, and that $g = \partial \varphi_0 / \partial n = l_0 \cdot n$ on $\partial \Omega$, which is a contradiction. The proof of proposition 3.2 is complete. \square

Combining theorems 2.1 and 3.1, we can state a *semi-global* stability result.

Corollary 3.3. *Let g be as in theorem 3.1, and let Λ be the map defined in (3.8). Let $K \subset \Omega_a$ be a compact set, and let $R > 0$ be a given number. Then there exists a constant $C = C(K, R, g) > 0$ such that for all $(h_1, l_1), (h_2, l_2) \in K \times \overline{B_R(0)}$ it holds*

$$\|\Lambda(h_1, l_1, g) - \Lambda(h_2, l_2, g)\|_{H^{s+1}(\Gamma_m)/\mathbb{R}} \geq C \|(h_1 - h_2, l_1 - l_2)\|_{\mathbb{R}^4}. \quad (3.22)$$

Proof. For any $(h_0, l_0) \in K \times \overline{B_R(0)}$, let $L_{h_0, l_0} : \mathbb{R}^4 \rightarrow H^{s+1}(\Gamma_m)/\mathbb{R}$ denote the linear map $L_{h_0, l_0} = d\Lambda(h_0, l_0, g)|_{\mathbb{R}^2 \times \mathbb{R}^2 \times \{0\}}$. Using the continuity of the map $(h_0, l_0, \hat{h}, \hat{l}) \mapsto L_{h_0, l_0}(\hat{h}, \hat{l})$, the compactness of $K \times \overline{B_R(0)} \times S^3$ and proposition 3.2, we infer the existence of two constants C_1, C_2 such that for any $(h_0, l_0) \in K \times \overline{B_R(0)}$,

$$C_1 \|(\hat{h}, \hat{l})\| \leq \|L_{h_0, l_0}(\hat{h}, \hat{l})\|_{H^{s+1}(\Gamma_m)/\mathbb{R}} \leq C_2 \|(\hat{h}, \hat{l})\| \quad \forall (\hat{h}, \hat{l}) \in \mathbb{R}^4. \quad (3.23)$$

On the other hand, the map $(h_0, l_0) \mapsto L_{h_0, l_0}$ being uniformly continuous on the compact set $K \times \overline{B_R(0)}$, we can find a small number $\delta > 0$ such that if $(h_0, l_0), (h'_0, l'_0) \in K \times \overline{B_R(0)}$ satisfy $\|(h_0, l_0) - (h'_0, l'_0)\| < \delta$, then

$$\|(L_{h_0, l_0} - L_{h'_0, l'_0})(\hat{h}, \hat{l})\|_{H^{s+1}(\Gamma_m)/\mathbb{R}} \leq \frac{C_1}{2} \|(\hat{h}, \hat{l})\| \quad \forall (\hat{h}, \hat{l}) \in \mathbb{R}^4. \quad (3.24)$$

Pick two pairs $(h_1, l_1), (h_2, l_2)$ in $K \times \overline{B_R(0)}$. Assume first that $\|(h_1 - h_2, l_1 - l_2)\| < \delta$, and set $\hat{h} = h_2 - h_1, \hat{l} = l_2 - l_1$. Then we have

$$\begin{aligned} \Lambda(h_2, l_2, g) - \Lambda(h_1, l_1, g) &= \int_0^1 \frac{d}{ds} \Lambda(h_1 + s\hat{h}, l_1 + s\hat{l}, g) ds \\ &= \int_0^1 L_{h_1+s\hat{h}, l_1+s\hat{l}}(\hat{h}, \hat{l}) ds \\ &= L_{h_1, l_1}(\hat{h}, \hat{l}) + \int_0^1 [L_{h_1+s\hat{h}, l_1+s\hat{l}} - L_{h_1, l_1}](\hat{h}, \hat{l}) ds. \end{aligned}$$

Using (3.23) and (3.24), we infer that

$$\|\Lambda(h_2, l_2, g) - \Lambda(h_1, l_1, g)\|_{H^{s+1}(\Gamma_m)/\mathbb{R}} \geq \frac{C_1}{2} \|(\hat{h}, \hat{l})\|.$$

If $\|(h_1 - h_2, l_1 - l_2)\|_{H^{s+1}(\Gamma_m)/\mathbb{R}} \geq \delta$, then

$$\|\Lambda(h_2, l_2, g) - \Lambda(h_1, l_1, g)\|_{H^{s+1}(\Gamma_m)/\mathbb{R}} \geq \frac{m}{d} \|(\hat{h}, \hat{l})\|,$$

where m denotes the minimum of the continuous map

$$(h_1, l_1, h_2, l_2) \mapsto \|\Lambda(h_2, l_2, g) - \Lambda(h_1, l_1, g)\|_{H^{s+1}(\Gamma_m)/\mathbb{R}}$$

taken over the compact set $\{(h_1, l_1, h_2, l_2) \in (K \times \overline{B_R(0)})^2, \|(h_2 - h_1, l_2 - l_1)\| \geq \delta\}$ and d denotes the diameter of that compact set. Note that $m > 0$, according to theorem 2.1. The proof is completed by taking $C = \min(m/d, C_1/2)$. \square

Remark 3.4. The constant C in theorem 3.1 is not given explicitly, as the method of proof relies upon compactness arguments. One way to give explicit values for this constant would be to estimate precisely the first eigenvalue of the linear map L in proposition 3.2.

Annexe

We prove in this annexe that the solution ψ of (2.17)–(2.19) cannot be of class C^2 at the point M_+ when $\delta \geq 1/\sqrt{2}$. Using the transformation $T_2 \circ T_1$ which is analytic in a neighbourhood of M_+ , its inverse being also analytic near the origin, this is equivalent to show that the solution ψ_2 of (2.24)–(2.27) is not of class C^2 at the origin. This is a direct consequence of the following result.

Proposition 3.5. Assume that $\delta \geq 1/\sqrt{2}$. Then the second derivative $\partial^2 \psi_2 / \partial y_2^2(0, 0)$ fails to exist.

Proof. Recall that $d_{-1} = \{z_2 \in \mathbb{C}^*; \arg z_2 = \theta^*\}$, where we denote $\theta^* = \theta_{-1} = \frac{\pi - \theta}{2}$. Obviously, $\delta \geq 1/\sqrt{2}$ if and only if $\theta^* \leq \pi/4$. Proving that ψ_2 is not of class C^2 in a neighbourhood of the origin is quite easy when $\theta^* = \pi/4$. Indeed, in that case we may use the system of orthogonal coordinates $(u, v) = (\sqrt{2})^{-1}(x_2 + y_2, -x_2 + y_2)$, with d_{-1} and d_0 as the coordinate axes, to compute the Laplacian of ψ_2 at the origin. If ψ_2 were of class C^2 near the origin, we should have

$$0 = \Delta \psi_2(0, 0) = \frac{\partial^2 \psi_2}{\partial u^2}(0, 0) + \frac{\partial^2 \psi_2}{\partial v^2}(0, 0).$$

But straightforward computations give

$$\frac{\partial^2 \psi_2}{\partial u^2}(0, 0) = \frac{\partial^2 \psi_2}{\partial v^2}(0, 0) = -2c^{-3} \neq 0.$$

When $\theta^* \neq \pi/4$, the value of the Laplacian of ψ_2 at the origin cannot be deduced from the knowledge of the second derivatives of ψ_2 along the axes d_{-1}, d_0 . An exact computation of ψ_2 is therefore required. This is done in the following step.

Step 1. *Reduction to a Dirichlet problem in the half-plane \mathbb{C}^+ .*

Let us introduce the number $\alpha > 1$ defined by

$$\alpha^{-1} := 1 - \frac{\theta^*}{\frac{\pi}{2}}.$$

Introduce the transformation $T_3(z_2) := z_3 = x_3 + iy_3 = (e^{-i\theta^*} z_2)^\alpha$. Then

$$T_3(d_{-1}) = \mathbb{R}^+, \quad T_3(d_0) = \mathbb{R}^- \quad \text{and} \quad T_3(C_2) = \mathbb{C}^+ := \{z = x + iy; y > 0\}.$$

Define ψ_3 on \mathbb{C}^+ by $\psi_3(z_3) = \psi_2(z_2)$. To determine the values of ψ_3 on $\partial\mathbb{C}^+ = \mathbb{R}$, we need to express z_2 as a function of z_3 when $z_3 = x_3 \in \mathbb{R}$.

If $z_3 = x_3 \in \mathbb{R}^+$, then $z_2 = e^{i\theta^*} x_3^{1/\alpha}$, and hence

$$\psi_3(z_3) = \frac{y_2}{(x_2 + c)^2 + y_2^2} = \frac{x_3^{1/\alpha} \sin \theta^*}{(c + x_3^{1/\alpha} \cos \theta^*)^2 + (x_3^{1/\alpha} \sin \theta^*)^2}.$$

If $z_3 = x_3 \in \mathbb{R}^-$, then $z_2 = e^{i\theta^*} |x_3|^{1/\alpha} e^{i\pi/\alpha} = |x_3|^{1/\alpha} e^{i(\pi - \theta^*)}$, and hence

$$\psi_3(z_3) = -\frac{y_2}{(x_2 + c)^2 + y_2^2} = -\frac{|x_3|^{1/\alpha} \sin \theta^*}{(c - |x_3|^{1/\alpha} \cos \theta^*)^2 + (|x_3|^{1/\alpha} \sin \theta^*)^2}.$$

Let us set $x^{(\alpha)} := \operatorname{sgn}(x)|x|^\alpha$ for any $x \in \mathbb{R}$ and any $\alpha \in \mathbb{R}^+$. Then ψ_3 solves the system

$$\Delta \psi_3 = 0 \quad \text{in} \quad \mathbb{C}^+, \quad (3.25)$$

$$\psi_3(x_3) = \frac{x_3^{\{1/\alpha\}} \sin \theta^*}{(c + x_3^{\{1/\alpha\}} \cos \theta^*)^2 + (x_3^{\{1/\alpha\}} \sin \theta^*)^2} \quad \text{on} \quad \mathbb{R}, \quad (3.26)$$

$$\psi_3(z_3) \rightarrow 0 \quad \text{as} \quad z_3 \rightarrow \infty, z_3 \in \mathbb{C}^+. \quad (3.27)$$

Using the Poisson formula (see, e.g. [7]), we obtain that

$$\psi_3(z_3) = \frac{y_3}{\pi} \int_{-\infty}^{\infty} \frac{\psi_3(t)}{|z_3 - t|^2} dt.$$

Going back to the variable $z_2 = r_2 e^{i\varphi_2}$, and using the fact that $z_3 = (e^{-i\theta^*} z_2)^\alpha = r_2^\alpha e^{i\alpha(\varphi_2 - \theta^*)}$, we conclude that

$$\begin{aligned} \psi_2(z_2) &= \frac{r_2^\alpha \sin \alpha(\varphi_2 - \theta^*)}{\pi} \int_{-\infty}^{\infty} \frac{t^{\{1/\alpha\}} \sin \theta^*}{(c + t^{\{1/\alpha\}} \cos \theta^*)^2 + (t^{\{1/\alpha\}} \sin \theta^*)^2} \\ &\quad \times \frac{dt}{(t - r_2^\alpha \cos \alpha(\varphi_2 - \theta^*))^2 + (r_2^\alpha \sin \alpha(\varphi_2 - \theta^*))^2}. \end{aligned}$$

For the value $\varphi_2 = \pi/2$, we obtain

$$\psi_2(0, y_2) = \psi_2(r_2 e^{i\pi/2}) = \frac{r_2^\alpha}{\pi} \int_{-\infty}^{\infty} \frac{t^{\{1/\alpha\}} \sin \theta^*}{(c + t^{\{1/\alpha\}} \cos \theta^*)^2 + (t^{\{1/\alpha\}} \sin \theta^*)^2} \frac{dt}{t^2 + |r_2|^{2\alpha}}.$$

In a second step, we show that $\lim_{y_2 \rightarrow 0^+} \frac{\partial^2 \psi_2}{\partial y_2^2}(0, y_2)$ exists and is finite if and only if $\alpha > 2$ (i.e. $\delta < 1/\sqrt{2}$).

Step 2. *Estimation of the second derivative of ψ_2 with respect to y_2 at the origin.*

Let us introduce the functions

$$f(t) = \frac{t^{\{1/\alpha\}}}{(c + t^{\{1/\alpha\}} \cos \theta^*)^2 + (t^{\{1/\alpha\}} \sin \theta^*)^2}, \quad g(r) = r \int_{-\infty}^{\infty} f(t) \frac{dt}{t^2 + r^2}$$

defined for $t \in \mathbb{R}$ and $r \in (0, +\infty)$, respectively. Note that $f \in C(\mathbb{R}) \cap L^\infty(\mathbb{R})$ with $|f(t)| \leq \text{const}(1 + |t|^{1/\alpha})^{-1}$. We aim to prove that for $\alpha \leq 2$, $|d^2[g(r^\alpha)]/dr^2| \rightarrow \infty$ as $r \rightarrow 0^+$. Using the Lebesgue theorem and a change of variables, we have

$$\begin{aligned} g'(r) &= \int_{-\infty}^{\infty} \frac{f(t)}{t^2 + r^2} dt - 2r^2 \int_{-\infty}^{\infty} \frac{f(t)}{(t^2 + r^2)^2} dt, \\ &= r^{-1} \int_{-\infty}^{\infty} \frac{f(rs)}{s^2 + 1} ds - 2r^{-1} \int_{-\infty}^{\infty} \frac{f(rs)}{(s^2 + 1)^2} ds, \\ g''(r) &= -6r \int_{-\infty}^{\infty} \frac{f(t)}{(t^2 + r^2)^2} dt + 8r^3 \int_{-\infty}^{\infty} \frac{f(t)}{(t^2 + r^2)^3} dt \\ &= -6r^{-2} \int_{-\infty}^{\infty} \frac{f(rs)}{(s^2 + 1)^2} ds + 8r^{-2} \int_{-\infty}^{\infty} \frac{f(rs)}{(s^2 + 1)^3} ds. \end{aligned}$$

It may be seen that $d[g(r^\alpha)]/dr \rightarrow 0$ as $r \rightarrow 0$; that is, $\partial\psi_2/\partial y_2(0, 0) = \lim_{y_2 \rightarrow 0^+} \partial\psi_2/\partial y_2(0, y_2) = 0$. On the other hand,

$$\begin{aligned} \frac{d^2[g(r^\alpha)]}{dr^2} &= (\alpha r^{\alpha-1})^2 g''(r^\alpha) + \alpha(\alpha - 1)r^{\alpha-2} g'(r^\alpha) \\ &= \alpha r^{-1}((\alpha - 1)I_1(r) + (-8\alpha + 2)I_2(r) + 8\alpha I_3(r)), \end{aligned}$$

where

$$I_j(r) := \int_{-\infty}^{\infty} \frac{s^{\{1/\alpha\}}}{c^2 + 2c(\cos \theta^*)rs^{\{1/\alpha\}} + (rs^{\{1/\alpha\}})^2} \frac{ds}{(s^2 + 1)^j} \quad \text{for } j \in \{1, 2, 3\}.$$

As $s \mapsto s^{\{1/\alpha\}}$ is odd, we see that $I_j(0) = 0$ for each j . Since

$$\left| \frac{2c(\cos \theta^*)s^{\{1/\alpha\}} + 2r|s|^{2/\alpha}}{(c^2 + 2c(\cos \theta^*)rs^{\{1/\alpha\}} + r^2|s|^{2/\alpha})^2} \frac{s^{\{1/\alpha\}}}{(s^2 + 1)^j} \right| \leq \text{const} \frac{|s|^{2/\alpha}}{(s^2 + 1)^j},$$

we infer from the Lebesgue theorem that

$$I'_j(r) = - \int_{-\infty}^{\infty} \frac{2c(\cos \theta^*)s^{\{1/\alpha\}} + 2r|s|^{2/\alpha}}{(c^2 + 2c(\cos \theta^*)rs^{\{1/\alpha\}} + r^2|s|^{2/\alpha})^2} \frac{s^{\{1/\alpha\}}}{(s^2 + 1)^j} ds \quad \forall r > 0$$

for any $\alpha > 1$ if $j \geq 2$, and for any $\alpha > 2$ if $j = 1$.

If $\alpha > 2$, then $\lim_{r \rightarrow 0^+} I_j(r)/r = I'_j(0)$ for $j = 1, 2, 3$, thus $\frac{\partial^2 \psi_2}{\partial y_2^2}(0, 0) = \lim_{y_2 \rightarrow 0^+} \frac{\partial^2 \psi_2}{\partial y_2^2}(0, y_2)$ exists.

Assume now that $1 < \alpha \leq 2$. Once again, $\lim_{r \rightarrow 0^+} I_j(r)/r = I'_j(0) \in \mathbb{R}$ for $j = 2, 3$. For $j = 1$, we claim that $I_1(r)/r \rightarrow -\infty$ as $r \rightarrow 0^+$.

Claim. $\lim_{r \rightarrow 0^+} I_1(r)/r = -\infty$.

Indeed, letting $\sigma = r^\alpha s$, we have that

$$I_1(r) = r^{-1-\alpha} \int_{-\infty}^{\infty} \frac{\sigma^{\{1/\alpha\}}}{c^2 + 2c(\cos \theta^*)\sigma^{\{1/\alpha\}} + |\sigma|^{2/\alpha}} \frac{d\sigma}{(\sigma/r^\alpha)^2 + 1},$$

hence

$$\begin{aligned} \frac{I_1(r)}{r^{\alpha-1}} &= \int_{-\infty}^{\infty} \frac{\sigma^{\{1/\alpha\}}}{c^2 + 2c(\cos \theta^*)\sigma^{\{1/\alpha\}} + |\sigma|^{2/\alpha}} \frac{d\sigma}{\sigma^2 + r^{2\alpha}} \\ &= -4c(\cos \theta^*)J(r), \end{aligned}$$

where

$$J(r) := \int_0^\infty \frac{\sigma^{2/\alpha}}{(c^2 + 2c(\cos \theta^*)\sigma^{1/\alpha} + \sigma^{2/\alpha})(c^2 - 2c(\cos \theta^*)\sigma^{1/\alpha} + \sigma^{2/\alpha})} \frac{d\sigma}{\sigma^2 + r^{2\alpha}}.$$

An application of the monotone convergence theorem yields $J(r) \rightarrow J(0)$ as $r \rightarrow 0^+$, where $J(0) \in (0, +\infty)$ for $\alpha \in (1, 2)$ and $J(0) = +\infty$ for $\alpha = 2$. The claim follows at once. The proof of proposition 3.5 is complete. \square

Acknowledgments

This work was achieved while the last author (LR) was visiting the Centro de Modelamiento Matemático at the Universidad de Chile (UMI CNRS 2807). He thanks this institution for its hospitality, the CNRS for its support and the ANR for a partial support through grant JCJC06-137283. The first author thanks the Millennium ICDB for partial support through grant ICM P05-001-F. The second author was partially supported by CONICYT-FONDECYT grant 3070040. The third author was partially supported by FONDECYT grant 1070148.

References

- [1] Alessandrini G, Beretta E, Rosset E and Vessella S 2000 Optimal stability for inverse elliptic boundary value problems with unknown boundaries *Ann. Scuola Norm. Sup. Pisa Cl. Sci.* **29** 755–806
- [2] Alessandrini G and Diaz Valenzuela A 1996 Unique determination of multiple cracks by two measurements *SIAM J. Control Optim.* **34** 913–21
- [3] Alessandrini G, Rosset E and Seo J K 2000 Optimal size estimates for the inverse conductivity problem with one measurement *Proc. Am. Math. Soc.* **128** 53–64
- [4] Alvarez C, Conca C, Friz L, Kavian O and Ortega J H 2005 Identification of immersed obstacles via boundary measurements *Inverse Problems* **21** 1531–52
- [5] Beretta E and Vessella S 1999 Stable determination of boundaries from Cauchy data *SIAM J. Math. Anal.* **30** 220–32 (electronic)
- [6] Doubova A, Fernández-Cara E and Ortega J H 2007 On the identification of a single body immersed in a Navier–Stokes fluid *Eur. J. Appl. Math.* **18** 57–80
- [7] Evans L C 1998 Partial differential equations *Graduate Studies in Mathematics* vol 19 (Providence, RI: American Mathematical Society)
- [8] Fabre C and Lebeau G 1996 Prolongement unique des solutions de l'équation de Stokes *Commun. Partial Diff. Eqns* **21** 573–96
- [9] Friedman A and Vogelius M 1989 Determining cracks by boundary measurements *Indiana Univ. Math. J.* **38** 527–56
- [10] Heck H, Uhlmann G and Wang J-N 2007 Reconstruction of obstacles immersed in an incompressible fluid *Inverse Problems Imaging* **1** 63–76
- [11] Henrici P 1974 Applied and computational complex analysis *Power Series—Integration—Conformal Mapping—Location of Zeros, Pure and Applied Mathematics* vol 1 (New York: Wiley-Interscience)
- [12] Houot J-G and Munnier A 2007 On the motion and collisions of rigid bodies in an ideal fluid *Asymptotic Anal.* at press
- [13] Kazhikhov A V 1981 Note on the formulation of the problem of flow through a bounded region using equations of perfect fluid *PMM USSR* **44** 672–4
- [14] Kohn R and Vogelius M 1984 Determining conductivity by boundary measurements *Commun. Pure Appl. Math.* **37** 289–98
- [15] Lions J-L and Magenes E 1972 *Non-homogeneous Boundary Value Problems and Applications* vol I, transl. ed P Kenneth (New York: Springer) (Die Grundlehren der mathematischen Wissenschaften, Band) p 181 (Translated from the French)
- [16] Majda A 1986 Vorticity and the mathematical theory of incompressible fluid flow *Commun. Pure Appl. Math.* **39** (Suppl.) S187–220 (Frontiers of the mathematical sciences, New York, 1985)
- [17] Marchioro C and Pulvirenti M 1994 Mathematical theory of incompressible nonviscous fluids *Applied Mathematical Sciences* vol 96 (New York: Springer)

- [18] Ortega J, Rosier L and Takahashi T 2005 Classical solutions for the equations modelling the motion of a ball in a bidimensional incompressible perfect fluid *Math. Modelling Numer. Anal.* **39** 79–108
- [19] Ortega J, Rosier L and Takahashi T 2007 On the motion of a rigid body immersed in a bidimensional incompressible perfect fluid *Ann. Inst. Henri Poincaré Anal. Non Linéaire* **24** 139–65
- [20] Rudin W 1987 *Real and Complex Analysis* 3rd edn (New York: McGraw-Hill)
- [21] Simon J 1980 Differentiation with respect to the domain in boundary value problems *Numer. Funct. Anal. Optim.* **2** 649–87
- [22] Sylvester J and Uhlmann G 1986 A uniqueness theorem for an inverse boundary value problem in electrical prospection *Commun. Pure Appl. Math.* **39** 91–112